

Silicon PIN Photodiode

AT40B-PD-12

Data sheet

REV. : 1.0

DATE : 20-Apr.-2010

Features:

- Fast Response Time.
- High Photo Sensitivity.
- Suitable for visible and near infrared radiation.
- Pb free
- The Product itself will remain within RoHS Compliant version.

Descriptions:

- AT40F-PD-02 is a high speed and high sensitive silicon PIN photodiode with exceptionally stable characteristics and high illumination sensitivity.
- Device is molded in clear epoxy package with a quadrate side view .

Applications:

- High Speed Photo Detector.
- Copier
- Game machine.

Internal Circuit:

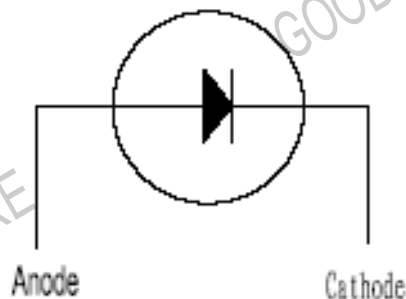

Absolute Maximum Ratings at Ta=25°C

Parameter	Symbol	Ratings	Unit
Power Dissipation	PD	215	mW
Reverse Breakdown Voltage	V(BR)	35	V
Operating Temperature	Topr	-25~+85	°C
Storage Temperature	Tstg	-40~+100	°C
Soldering Temperature	Tsol	270°C for 6 sec Max (2mm from Body)	

Typical Electrical & Optical Characteristics (Ta=25°C)

Parameter	Symbol	Min.	Type	Max.	Unit	Test Condition
Reverse Light Current	I _L	45	55		μA	V _R =5V, λ _p =940nm E _e =1mW/cm ²
Reverse Dark Current	I _D		2	30	nA	V _R =10V, λ _p =940nm E _e =0mW/cm ²
Reverse Breakdown Voltage	V _{BR}	35			V	I _R =100μA E _e =0mW/cm ²
Wavelength of peak sensitivity	λ _p		940		nm	
Range of spectral band width	λ	430	---	1100	nm	
Rise Time	T _r		50		ns	V _R =10V λ _p =940nm R _L =1000Ω
Fall Time	T _f		50		ns	
Total Capacitance	C _T		25		Pf	V _R =3V E _e =0mW/cm ² f=1.0MHZ
View Angle	2θ _{1/2}	---	65	---	°	I _F =20mA

Basic Characteristics ($T_{\text{amd}}=25^{\circ}\text{C}$, unless otherwise specified)

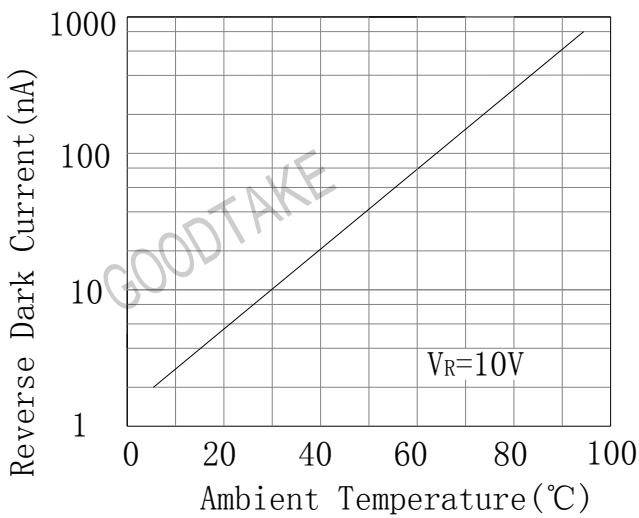

Fig. 1 Reverse Dark Current VS. Ambient Temperature

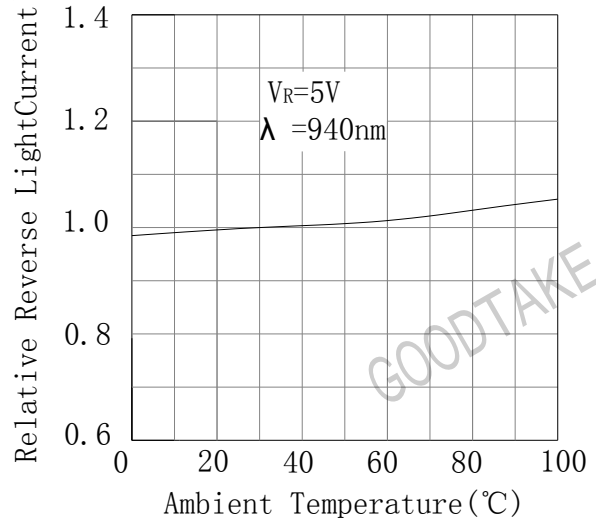

Fig. 2 Relative Reverse Light Current VS. Ambient Temperature($^{\circ}\text{C}$)

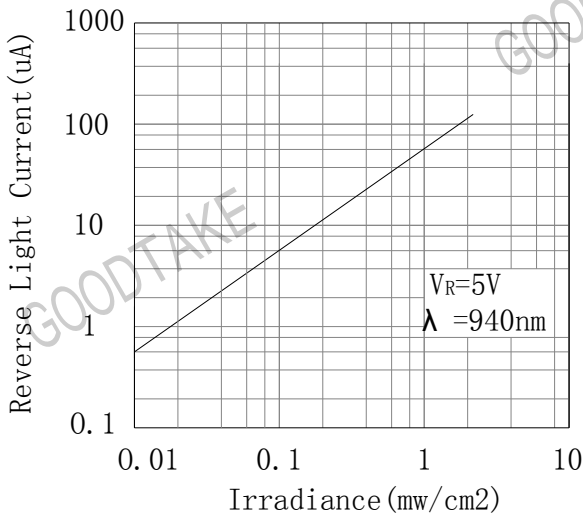

Fig. 3 Reverse Light Current VS. Irradiance

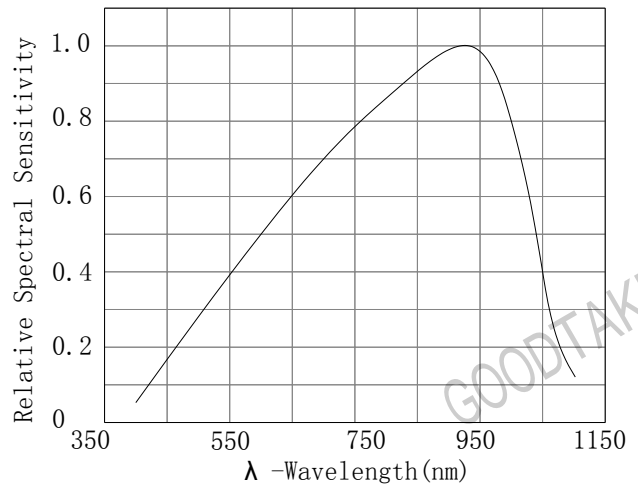

Fig. 4 Relative Spectral Sensitivity VS. Wavelength

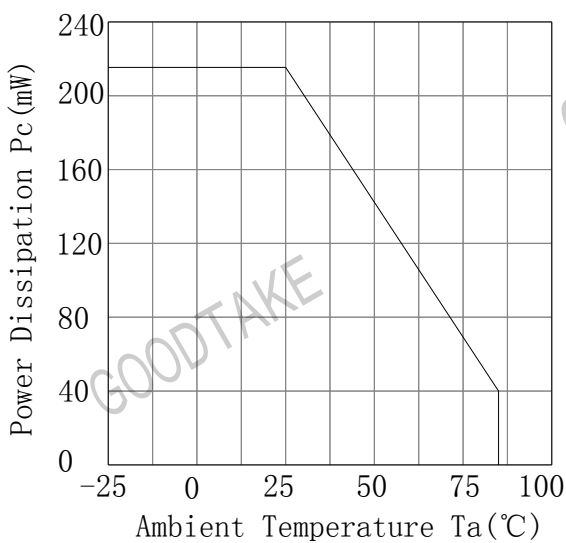

Fig. 5 Power Dissipation VS. Ambient Temperature

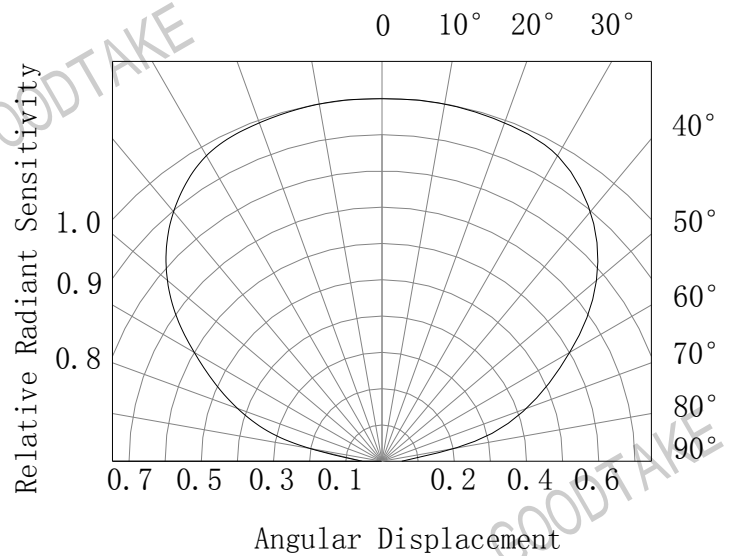

Fig. 6 Relative Radiant Sensitivity VS. Angular Displacement

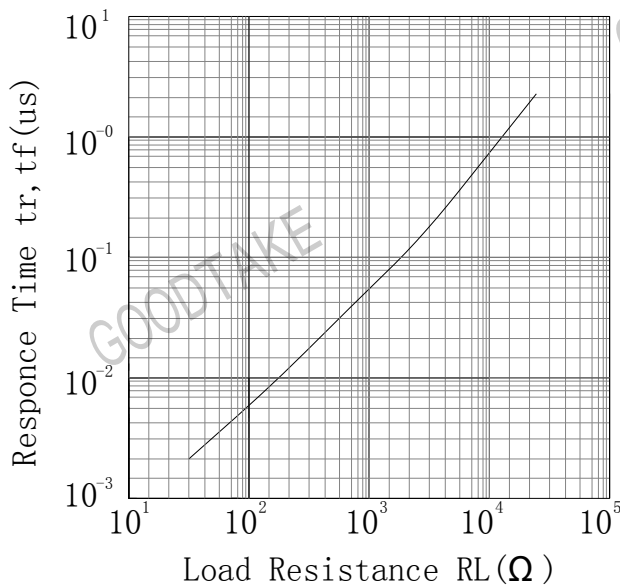

Fig. 7 Response Time VS Load Resistance

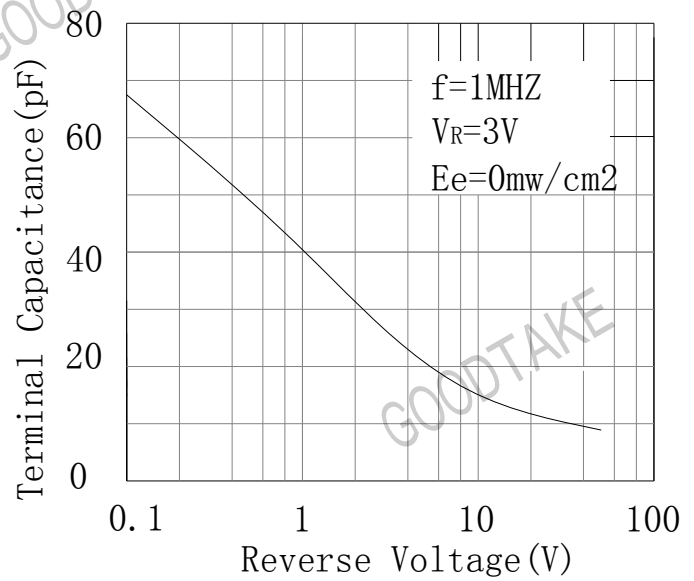

Fig. 8 Terminal Capacitance VS. Reverse Voltage

Reliability Test Items and Conditions:

NO	Item	Test Conditions	Test Hours/Cycle	Sample Quantity	Test Result
1	Solder Heat	TEMP: 270°C ±3°C	10 SEC	11 pcs	0 DEFECT
2	Temperature Cycle	H:+85°C 60min ↓ 10min L:-25°C 60min	16 cycles	22 pcs	0 DEFECT
3	Thermal Shock	H:+85°C 30min ↑ 30sec L:-25°C 30min	10 cycles	11 pcs	0 DEFECT
4	High Temperature Storage	TEMP: +85°C	1000 HRS	22 pcs	0 DEFECT
5	Low Temperature Storage	TEMP: -25°C	1000 HRS	22 pcs	0 DEFECT
6	High Temperature High Humidity Storage	85°C/93% RH	1000HRS	22 pcs	0 DEFECT

Package DimensionS:

Center of sensitive area

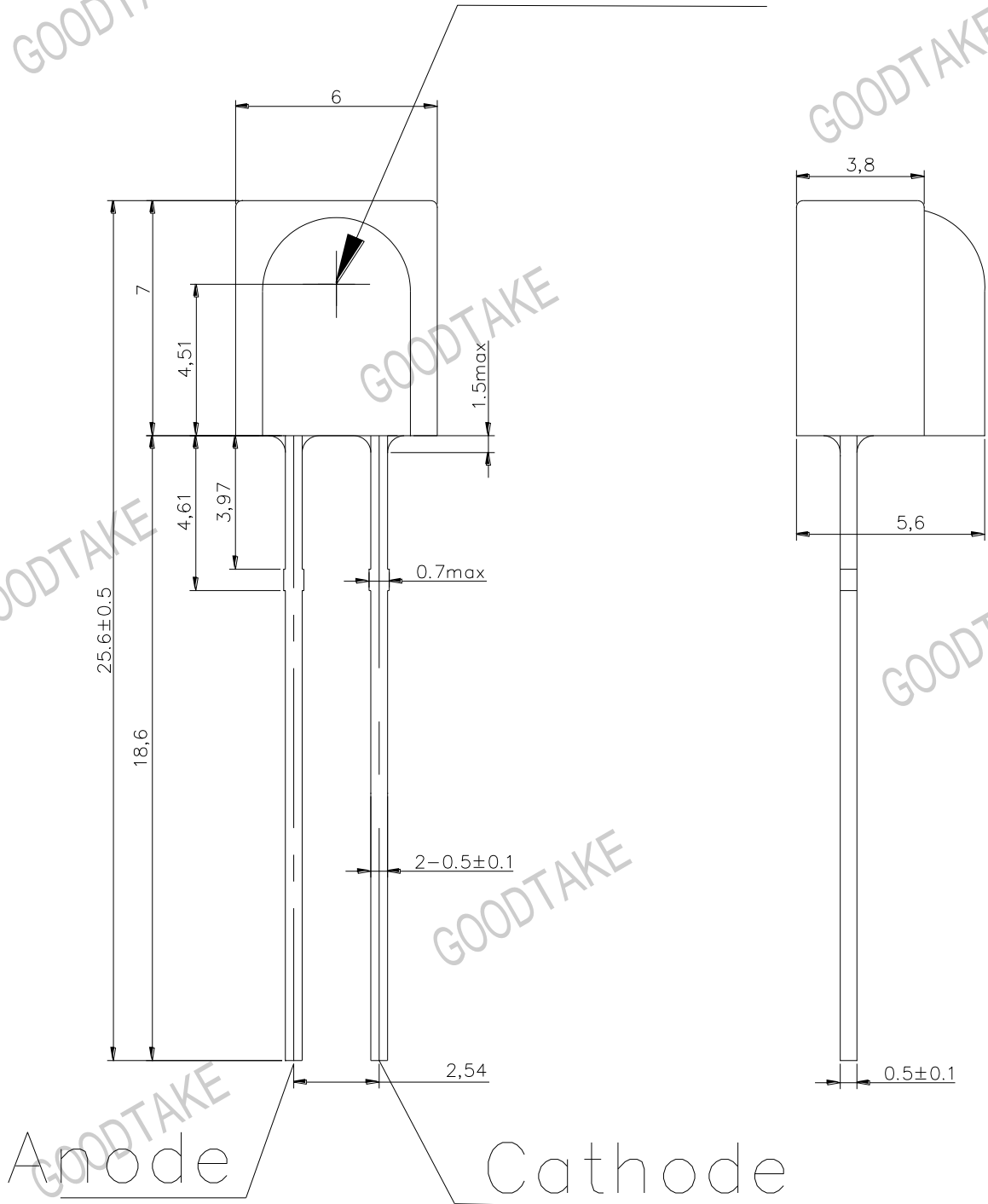

- NOTE:** 1. All dimensions are in millimeter, tolerance is ± 0.2 unless otherwise noted.
2. Epoxy meniscus extends ≤ 1 mm down to the lead is allowed.